

Installation Instructions

Models #CB850, CB1050, CB1250

NOTE: For best operation, install solar fan where it will receive direct sunlight. A South or West facing slope will work best.

- 1) Determine roof rafter spacing.
 - a.) **16" Rafter Spacing:** Cut a 14 1/2" square hole between rafters approximately 24" down from roof peak to center of hole.
 - b.) **24" Rafter Spacing:** Cut a 16 3/4" square hole between rafters approximately 24" down from roof peak to center of hole.
- 2) Build a 19 3/4" x 19 3/4" curb with treated lumber and secure to roof deck.
- 3) The picture to the right shows how the curb might be flashed if on a pitched roof. On a flat or low-slope roof the curb can be flashed with EPDM rubber, modified bitumen, hot tar/felt, or other appropriate material.
- 4) Run a generous bead of sealant along top edge of curb.
- 5) Pre-drill (8) mounting holes, (2) per side, on the base skirt of the SunRise.
- 6) Place the SunRise over curb with SRS Logo on the bottom, making sure it is seated into sealant. Using exterior-grade screws, secure unit to curb.

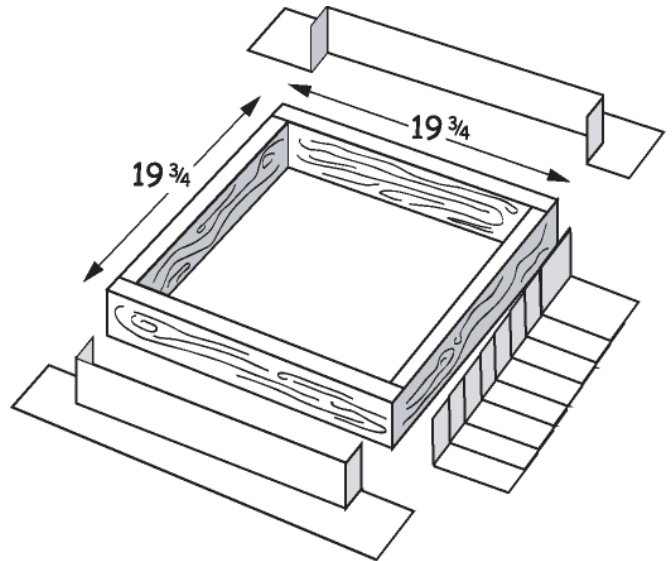

**DO NOT OVER-TIGHTEN SCREWS, AS THIS MAY CAUSE
UNIT BASE TO CRACK OVER TIME.**

